

# VYNCO

## INSTALLATION INSTRUCTIONS AND SPECIFICATIONS for IC-4 & IC-F rated Diaz Step Light - VST1, VST1B & VST1S

### SPECIFICATIONS

Voltage:	230-240V a.c. 50Hz
Wattage:	3W
Luminaire Class:	Class 1
Lumen Output	80 Lm
Colour Temperature:	3000k
Degree of Protection:	When installed: Front IP44 Back: IP20

### Dimmable

For optimal results, use Digital LED Dimmer - VT1D450LSWE. Other approved dimmers: Vynco, Clipsal, HPM and PDL trailing edge dimmers.

### Safety

This product should be installed by a suitably qualified person in accordance with Australian and New Zealand Wiring rules. Always disconnect the power to the fitting before removing any covers. In the case of lamp failure, disconnect from mains supply and return to Vynco, if still within the warranty period.

This light **MUST** be installed into a flush box, mounted behind wall cladding with the use of two screws. Screws heads must be covered with plastic caps.

**RISK OF FIRE** - Required clearance from structural members and building elements

SCB = 0mm	MIC = 0mm
HCB = 0mm	SCI = 0mm

**WARNING - RISE OF OVERHEATING OF FIRE IF THE CLEARANCE DISTANCES ARE COMPROMISED.**

**HCB:** Height clearance to building element

**MIC:** Minimum insulation clearance

**SCI:** Side clearance to insulation

**SCB:** Side clearance to building element

### CLEARANCES FROM COMBUSTIBLE MATERIAL:

This luminaire has been independently tested and is rated for IC-4 and IC-F installation.

This product is suitable for use with building insulation that can safely be continually exposed to temperatures up to 90°C and must withstand a 30s needle flame test carried out in accordance with AS/NZS 60695.11.5 with the flame applied to all surfaces of the sample.

Loose fill insulation as defined in NZS 4246 is not permitted to abut or cover this luminaire.

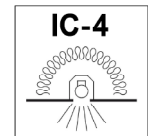
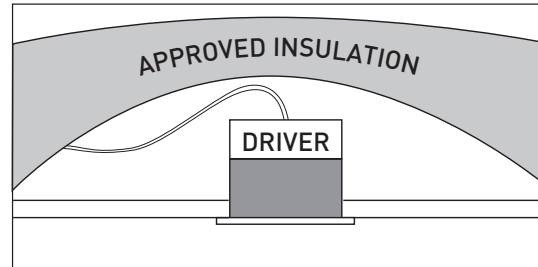

### Warranty

This product is covered by the standard 3 year Vynco Warranty - proof of purchase is required. Please contact Vynco for details of returns procedure.

**NOTE: This product contains NO user serviceable parts. And shall only be replaced by the manufacturer, his service agent or a similar qualified person.**

# VYNCO

## INSTALLATION INSTRUCTIONS AND SPECIFICATIONS for IC-4 & IC-F rated Diaz Step Light - VST1, VST1B & VST1S

### INSTALLATION

#### Wiring Instructions

L = Phase N = Neutral  $\oplus$  = Earth

- This light MUST be installed into a flush box, mounted behind wall cladding (minimum 10mm thick) with the use of two screws.
- Using a suitable tool cut a hole around the internal perimeter of the flush box, including notches to access the threaded screw bosses.
- After ensuring circuit is isolated, terminate wiring in an approved manner.
- Insert the light into the opening and secure in place with the two provided screws.
- Screw heads must be covered with the supplied screw caps.
- Energise and test.
- Clip the fascia plate onto the light, the fascia can be levelled using 2 degrees of rotation provided by the fascia.

**The light source of this luminaire is not replaceable; when the light source reaches its end of life the whole luminaire shall be replaced.**

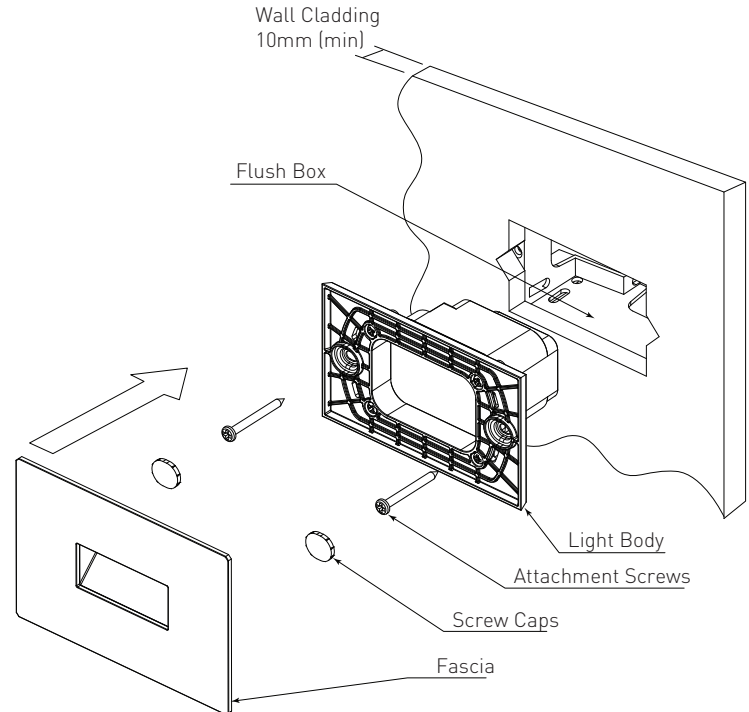

Vynco Industries (NZ) Ltd Phone +64 3 379 9283 or +64 9 525 6051